

OWNER'S MANUAL

AIR-COOLED DIESEL GENERATOR SET

Model HDD7000E



Technology Corporation of America



Heavy Duty Power System Technology
Corporation of America
Phone #: 208-949-1121

PREFACE

Thank you for purchasing products from our company .We appreciate your business. The following manual is only a guide to assist you and is not a complete or comprehensive manual of all aspects of maintaining and repairing your generator. The equipment you have purchased is a complex piece of machinery. We recommend that you consult with a dealer if you have doubts or concerns as to your experience or ability to properly maintain or repair your equipment. You will save time and avoid the inconvenience of having to go back to the store if you choose to write or call us concerning missing parts, service questions, operating advice, and/or assembly questions. Our air-cooled diesel generators have some of the following features:

- Lightweight construction
- Air cooled
- Four-stroke diesel internal combustion engine
- Direct fuel injection system
- Recoil starter or an optional electric starter
- Large fuel tank
- Automatic voltage stabilizer
- NFB circuit protector
- AC and DC outputs
- Low oil pressure sensor

H.D brand air-cooled diesel generators are widely used when electrical power is scarce. Our generators provide a portable mobile solution in supplying power for field operations during project construction. Some other known applications include pipeline construction and metal welding when electrical power is not available.

This manual will explain how to operate and service your generator set.

If you have any questions or suggestions about this manual, please contact your local dealer or us directly. ***Consumers should notice that this manual might differ slightly from the actual product as more improvements are made to our products. Some of the pictures in this manual may differ slightly from the actual product as well. H.D POWER reserves the right to make changes at any time without notice and without incurring any obligation.***

TABLE OF CONTENTS

Chapter 1 Technical Specifications and Data	1
1-1 Technical specifications and data.....	1
1-2 Basic operating parameters.....	2
1-3 General dimensions and overview of the generators.....	2
Chapter 2 Operating the Diesel Generator	3
2-1 Main points of safety during operation of the generator.....	3
2-2 Preparation before operation.....	4
2-3 Checking the operation of the diesel engine.....	7
2-4 Starting the generator set.....	7
2-5 Proper operation of the generator set.....	8
2-6 Loading.....	9
2-7 Stopping the generator.....	10
Chapter 3 Maintenance	11
3-1 Maintenance schedules.....	11
3-2 Storing for long periods of time.....	12
Chapter 4 Troubleshooting	13
4-1 Troubleshooting procedures.....	13
4-2 Questions and doubts.....	13
Chapter 5 Generator Parts Diagrams and Listings	14
Chapter 6 Circuit diagram	20

CHAPTER 1 TECHNICAL SPECIFICATIONS AND DATA

1-1 Technical specifications and data

H.D Single-cylinder diesel generator

Model Item	HDD7000E	HDD7000E3
Rated frequency (Hz)	60	60
Rated voltage (V)	220、230、240、110/220、 115/230、120/240	380/220、400/230、420/240
Rated output power (kVA)	5.0	5.0
Max output power (kVA)	6.3	6.3
Rated rotation speed (rpm)	3600	3600
Power factor cosφ	1	1
Phase number	Single	Three
Pole number	2	3
Excitation Transistorized	self-excitation , Brushless	self-excitation constant voltage (AVR)
ATS type	without ATS	without ATS
Fuel consumption (g/kw.h)	340	340
Fuel tank capacity (L)(US.gal)	14.5(3.8)	14.5(3.8)
Continuous running time (hr)(at rated power)	8	8
Noise level [dBA/7m] (zero load~full load)	69-74	69-74
Net weight (kg)(US.lbs)	165(363)	165(363)
Overall dimension [mm](L×W×H)(US.inch)	920×520×700 (36.2×26.5 ×27.6)	920×520×700 (36.2×26.5 ×27.6)
Starter system	electric starter	electric starter
Fuel type	0# (summer), -10# (winter), -35#(chill cold) diesel	0# (summer), -10# (winter), -35#(chill cold) diesel
Lube oil brand	CD or better than CD	CD or better than CD
Engine model	CF186F(E)	CF186F(E)
Engine type	Single cylinder, 4-stroke,air-cooled,vertical, diesel engine	Single cylinder, 4-stroke,air-cooled,vertical, diesel engine
Bore × stroke(mm)	86×72	86×72
Displacement(cm ³)	0.418	0.418
Compression ratio	19: 1	19: 1
Rated power [kW(Hp)/rpm]	5.8(7.9)/3600	5.8(7.9)/3600
Max. power [kW(Hp)/rpm]	7.3(10.0)/3600	7.3(10.0)/3600
Rotation direction(from the flywheel)	clockwise	clockwise

Note: Get this power only after 30 hours' initial run.

1-2 Basic operating parameters

1-2.1 Under the given conditions, the generator will output the specified power in the table listed below.

Table 1

Height above sea level (ft)	Ambient temperature (° F)	RH
0	+60 (+20 ° C)	60%
<3280.8 (<1000 m)	41~104 (5-40 ° C)	90%

1-3 General dimensions and overview of the generators

1-3.1 HDD7000E dimensions of the series generator.

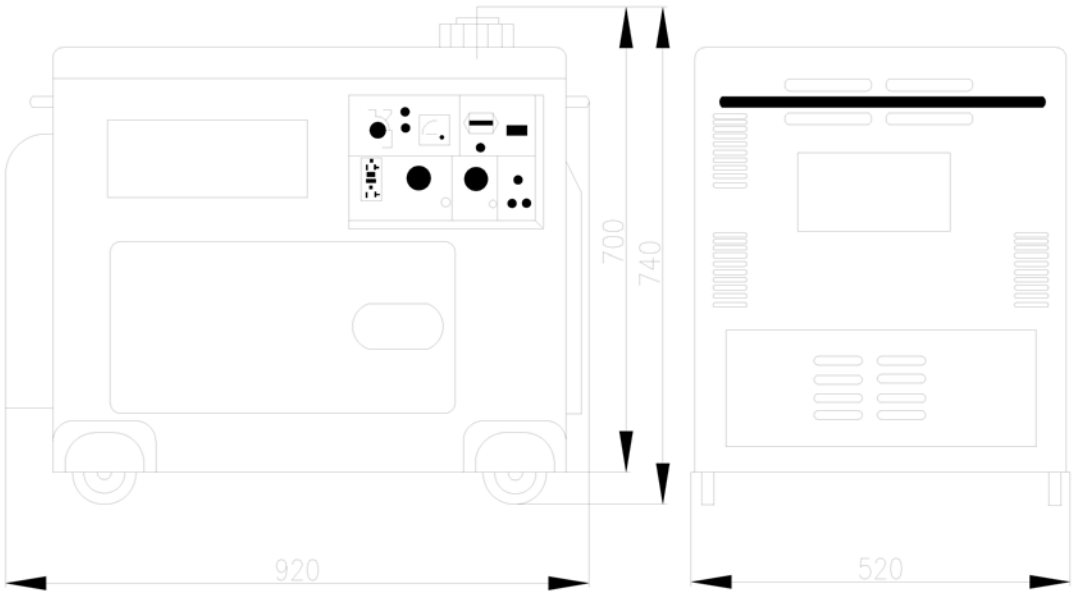

CHAPTER 2 OPERATING THE DIESEL GENERATOR

2-1 General main points of safety during operation of the generator set.

In order to operate the generator set safely, please follow all the instructions provided in this manual carefully. Doing so otherwise may lead to accidents or equipment damage.

2-1.1 Fire prevention

The proper fuel for the diesel generator set is light diesel fuel. Do not use gasoline, kerosene or other fuels other than light diesel fuel. Keep all flammable fuels away from the generator as the generator may spark and ignite these gases. In order to prevent fires from occurring and to provide enough ventilation for people and the machine, keep the diesel generator at least 1.5 meters away from buildings and or other equipment. Always operate your diesel generator on a level site. If the generator is operated on an incline, the lubricating system within the engine will not perform well and may lead to failure of the engine.

2-1.2 Prevention from inhaling exhaust gases.

Never inhales exhaust gases emitted by the engine. The exhaust gases contain toxic carbon monoxide. Never operate your generator in places with poor ventilation. In order to operate this machinery indoors, a suitable ventilation system for the building is required to draw the poisonous exhaust gases out.

2-1.3 Prevention from accidental burns

Never touch the muffler and its cover when the diesel engine is running. Never touch the muffler and cover after the diesel engine has been used, as the muffler remains hot for a good period of time.

2-1.4 Electric shock and short circuits

Never touch the generator if the generator is wet. Also never touch the generator if your hand is wet. Never operate your generator if the weather conditions call for any type of precipitation such as rain, snow, or fog. To prevent electrical shocks, the generator should be grounded. Use a lead to connect the grounding end of the generator to the grounding surface of choice. Please refer to Fig. 2-1 before beginning to use the electric generator.

Fig. 2-1

Note: When connecting devices to the generator, make sure all other devices are rated lower than the generators output. Any generator socket should not be overloaded over its regulated limit.



2-1.5 Other safety points

Before operating this generator, all operators should have a good knowledge of how to break the circuit if any accidents occur. Also, all operators should be familiar with all the switches and functions of the generator before using this machine. While operating the generator, wear safe shoes and suitable clothes during operation. Always keep children and animals away from the generator.

2-1.6 Battery

The electrolytic liquid of the battery also known as battery acid contains sulfuric acid. In order to protect your eyes, skin, and clothing, wears protective gear when working with the battery. If you come in contact with the electrolytic liquid, wash it immediately with clean water. Also, if the electrolytic liquid comes in contact with your eyes, see a doctor immediately.

2-2 Preparation before operation

2-2.1 Fuel choices and fuel treatment

Fuel tank

Use only light diesel fuel. The fuel should be filtered clean. Never let dust and water mix with fuel in the fuel tank. Otherwise it will clog the fuel lines and oil nozzles. It may also damage your pressure pump.

Note: It is dangerous to overfill the fuel tank. Never exceed the red piston in the filter.

Type	HDD7000E	HDD7000E
The effective volume of fuel tank: (L)(US. gal)	14.5 (3.8)	14.5 (3.8)

- a. After purchasing fuel, put it into a drum and let it sit for 3-4 days.
- b. 3-4 days later, insert half of the fuel sucker into the drum, (water and impurities stay in the lower portion of the drum)

NOTE: Never smoking near the opening of the fuel tank. Do not let sparks get near the fuel or fuel tank and do not overfill tank. After filling, tighten the fuel cap.

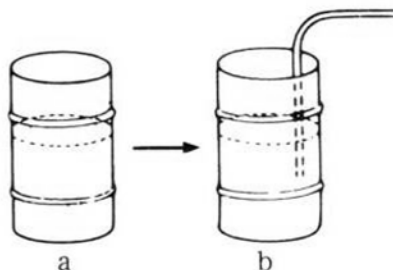

Air filter element

Do not wash the air filter. The element is made of dry material, which does not permit washing. When the output of the diesel engine is bad or the color of the exhaust gas is abnormal, replace the air filter element. Never start the diesel engine without the air filter.

Air filter



2-2.2 Filling engine oil

Remove the dipstick from the engine

Make sure the generator is on level ground, and fill the engine with 15W40 engine oil. Put the dipstick back into the hole to check the engine oil level.

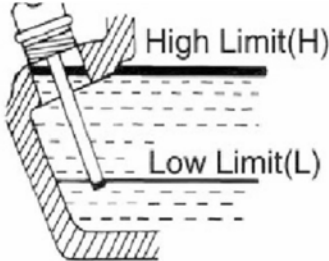

Capacity	Model	CF186F
Litre (US. gal)		1.65 (0.44)

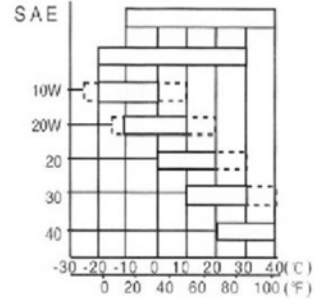

Be sure to use SAE 10W30, API grade CD or higher

Engine oil is the most important factor in determining the life of your generator engine. If you use poor engine oil or if you don't change the oil regularly, the piston and cylinder will wear easily or seize up. Also, the life of the other parts in your engine such as bearings, and other rotating parts will shorten considerably.

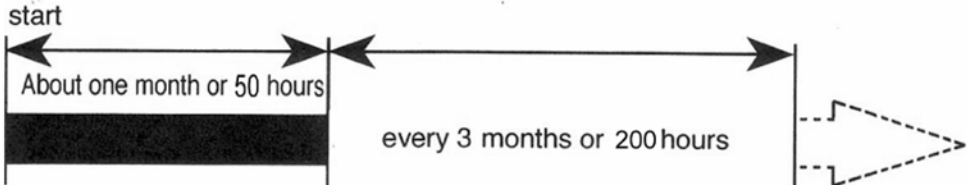

Interval of Changing Machine Oil

Although there is an alarm system to check for low oil pressure, it is always a good idea to check the amount of oil inside the engine. If the oil level is low, fill it before starting the engine. A good time to drain the oil from the engine is when the diesel engine is still hot. If the engine is fully cooled, it is more difficult to drain all the oil out or some impurities will remain in the engine.

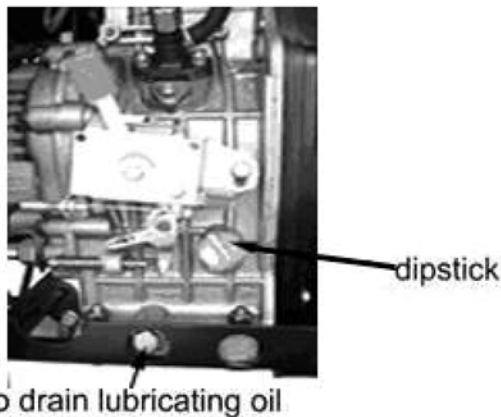

Warning: Don't fill engine oil when diesel is operating.

2-2.3 Checking the air filter



(1) Loosen the butterfly nut, take the cover of the air filter off and take the air filter element out.

Do not use detergent to wash the air filter element. When the performance of the engine decreases or when the color of the exhaust gases is bad, exchange the filter element. Never start the engine without the air filter as foreign objects may enter the intake and damage the engine.

Air filter



(2) After replacing the air filter element, replace the cover and tighten the butterfly nut firmly.

Air filter cover

Use dry compressed air (with pressure about 1.96×10^5 Pa) to blow the dust out in the electric control cabinet and at the surface of the generator. Check to see how clean the surface of the sliding ring is. Check the pressure of the carbon brush. Also, check whether the position of the carbon brush at the slide ring is correct and the fixture is reliable with a good contact.

According to the electric wiring diagram, check to see whether the connecting wire is correct and the connected place is firm.

Use a 500 M Ω meter to measure the insulation resistance of the electrical part. The resistance should be no less than 5M Ω . When measuring devices, make sure the AVR is turned off. Otherwise, it will burn the AVR. (For the low noise set, the inspection may not be performed).

2-2.4 The fuel and oil in a new engine is drained before sold. Before you start the engine, please fill the fuel tank and engine oil first. Then, check to see if there are air bubbles in the engine. If there are, follow these procedures. Loosen the connecting nut between the oil injection pump and oil pipe. Bleed the air from the system until there are no more bubbles. Then replace the connecting nut and tighten it.

2-3 Checking the operation of the diesel engine

2-3.1 Low-pressure alarm system.

H.D diesel engines have a low-pressure sensor system where if the oil pressure drops too low, the sensor will shut the engine off. The purpose of having this system is to ensure that the engine does not seize up. If there is not enough oil in the engine, the temperature of the oil will be raised too high. On the contrary, if there is too much oil in the engine, the engine oil can slow the engine down considerably.

2-3.2 How to open the case door/cover

- (1) Open the case door: Pull the handle outward and open the door. Do these checks daily.
- (2) Loosen the outer cover bolt of the air filter and outer cover of the oil nozzle, and then check the air filter.
- (3) Check the outer cover of the oil nozzle. Loosen the butterfly nut and open the outer cover.

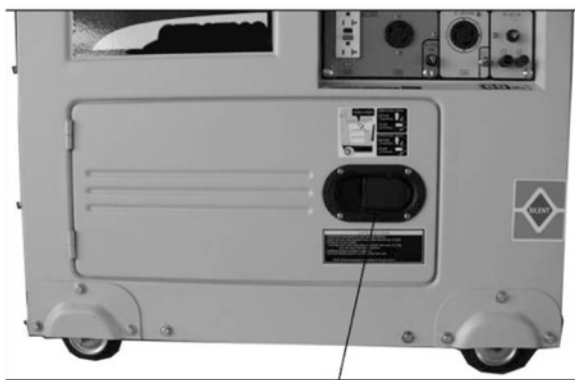

Knobhandle

2-3.3 Engine break in

When you purchase a brand new engine, the engine must be properly broken in. The break in period is about 20 hours.

- (1) Avoid overloading the engine when brand new
- (2) Change the engine oil according to specifications. An oil change for a brand new engine is about 20 hours or every month, an older engine, the oil change is about 100 hours or three months.

2-4 Starting the generator set

2-4.1 Starting.

Start the engine in accordance with procedures below:

- (1) Open the front door to put the speed handle to right side, namely "on" position.
- (2) Turn the ignition switch of the engine to the "Start" position for 1~2 seconds.
- (3) After starting the engine, loose the ignition switch and it will return to "On" position automatically, the engine start to work.
- (4) If fail to start, please restart the engine as above steps after 15 seconds.

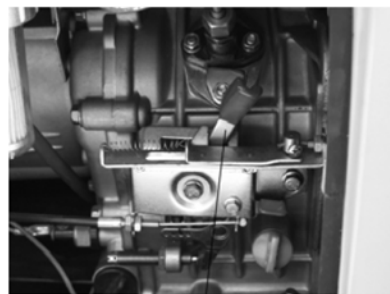

Speed handle

2-4.2 Battery

1. Insert key into ignition and put it in the “off” position.
2. Put the speed handle in the “Run” position.
3. Turn the start switch clockwise to the “START” position.
4. After the diesel engine is started, remove your hand from the switch handle; the switch will automatically reset itself to the “ON” position.
5. If the engine is not starting after 10 seconds of cranking, wait about 15 seconds before trying it again. If you crank too long, the voltage of the battery will drop. This can lead to improper ignition. When the diesel engine is operating, let the ignition retain on the “ON” position.

Note: If you crank the starter too long, the battery may be drained too much to provide enough energy for proper engine ignition. Also, when the diesel engine is operating, let the key retain in the “ON” position.

Important Notice:

All of our units come with a maintenance free battery. You do not need to add any battery acid.



2-5 Proper operation of the generator set

2-5.1 Operating the diesel engine

1. Pre-heat the diesel engine for 3 minutes under no load conditions.
2. First check the height of the lubricating oil level, if it is low, refill it. Our diesel engines are equipped with an alarm system that will notify you if the oil pressure is too low. The alarm system will shut down the engine if the oil pressure is too low.

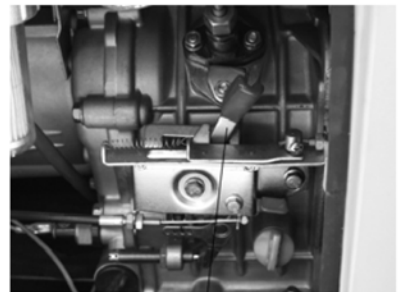

Speed handle

3. Do not adjust the speed limit regulation bolt or the fuel adjustment bolt. These bolts have been set by the factory already, changing them will affect the properties of the engine performance.

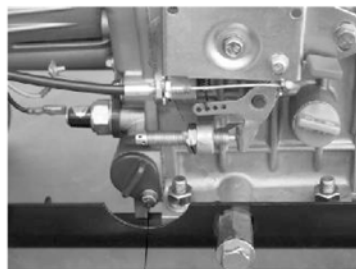

High-pressure fuel pipe bolt

2-5.2 Checks during engine operation

1. Check to see if there are abnormal noises.
2. Check to see if the performance is good or bad
3. Check the color of the exhaust gases (whether it is too black or too white). If any of these conditions exist, stop the engine and find the cause of the problem. If no problems are found, please contact your local dealer or our nearest company branch.

2-6 Loading

2-6.1 Load conditions

Exert loads in accordance with the specified parameters.

2-6.2 Output of electricity

1. Raise the revolutions per minute (turn the speed handle to the max setting) of the generator to get the maximum power out of the generator. If not, the automatic voltage regulator device will excite and doing this for long periods of time will cause the AVR to burn. For the rated speed of the generator, please refer to Chapter 1, item 1-1 technical specification and data.
2. Observe the pointer of the voltmeter; it should point to 240 V 5% (60Hz). Meanwhile put the switch in the GEN (generator) position. The AC voltage from the socket of the power supply can be output.
3. When connecting devices to the generator, make sure to connect these devices in order. Connect the large loads onto the generator first. If everything is functional, smaller loads can then be added. If the generator shuts off, it may be because the load being drawn by all the various devices are too high. In this event, decrease the number of small devices until everything is functional. The total drawn power should not exceed the maximum output power of the generator. Please see Table 1-1 for technical specifications of what the generator can output. In order to reset the generator after overdrawn power, let it sit for several minutes. If the indication of the voltmeter is too high or too low, adjust the speed accordingly. If there are problems, stop the generator immediately and fix the issue.
4. During operation, the generator should be in a place that has very good ventilation. Never cover the engine to solve a ventilation problem, as this will damage your equipment.

Note: Do not start more than two devices simultaneously. Each device should be started one by one to prevent overloading the generator.

The generator should be running at 3600 revolutions per minute in order to achieve the (60 Hz) frequency. The speed of the engine can be adjusted from the speed governor.

2-6.3 Charging the battery

1. For the electric starter on the generator sets, the 12V battery is automatically charged through the regulator on the side of the engine when it is running.
2. If the generator is not used for long periods of time, the battery should be disconnected to avoid energy loss from the battery.
3. Do not connect the negative and positive terminals of the battery together at any time. Doing so will damage the battery and cause serious injuries.
4. Do not reverse the polarities when attaching the battery cables to the battery. Doing so will damage both the battery and the electric starter.
5. When charging the battery, the battery produces flammable gases. Do not smoke, let flames, and sparks get near the battery while it is charging as this may cause a fire.

To avoid sparking while connecting the cables to the battery, first, connect the cables to the battery then to the motor. To disconnect battery cables, first disconnect the motor end of the cable.

2-7 Stopping the generator

1. Take the electrical load off the generator.
2. Put the speed handle in the "RUN" position and let the engine run for 3 minutes after unloading. Do not stop the diesel engine immediately let it warm down. Stopping the diesel engine suddenly may raise the temperature of the engine abnormally and lock the nozzle and damage the diesel engine.

Note:

1. If you cannot stop the engine with a load on it, then remove the load first than stop the engine.
2. Press down on the brake handle.
3. If equipped with an electric starter, turn the key to the "Off" position.
4. Put the fuel handle to the "S" position.

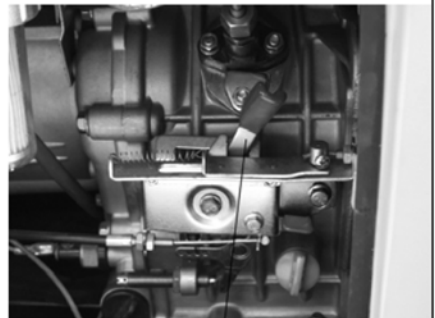

Speed handle

CHAPTER 3 MAINTENANCE

3-1 Maintenance schedules

Keeping your generator well maintained will prolong the life of your generator. Everything needs to be checked including the diesel engine, generator, control cabinet, and frame. For overhauling procedures, please refer to the instruction manual of the relative subassembly. If you need these manuals, please call our company and we will send you one.

Before starting the maintenance, make sure the diesel engine is off.

Please refer to the Table 3-1 for the proper maintenance schedule.

Table 3-1. Maintenance schedule for diesel generator set

Time Item	Everyday	After 1 month or 50hours	Every 3 month or 200 hours	Every 6 month or 400 hours	Every 1year or 1000 hours
Check the fuel level and refill	○Before starting				
Drain the fuel tank		○			
Check and fill enough engine oil	○				
Clean the fuel filter			○		
Check fuel oil leakage	○after every operating				
Check and screw each fastened part	○			●screw the bolt of cylinder head firmly	
Check injector				●	
Check injection pump					●
Check fuel pipe				●If necessary exchange it	
Check the lube. oil level in the oil pan and refill	○before starting				
Replace the lube. oil		○the first time	○the second time and afterward		
Clean lube. Oil filter		○the first time	○the second time and afterward		
Check the air cleaner element		○the first time	○the second time and afterward		
Change the core of air filter	If damaged or smeary , change it in time				
Check the battery liquid level and refill	○				
Adjusting the intake and exhaust valve clearance		●the first time		●the second time and afterward	
Grind air intake and air exhausted gate					●
Exchange piston ring					●
Check electric brush and slide ring				●	
Check insulation resistance	The time of stop is over 10 days ○				

Note: the quality period of the injector and injection pump is 1500 hours or two years. There into,● means it should operate with special tools, or can be checked by dealer.

3-1.1 Changing the engine oil (every 100 hours)

Take the oil cover off. Remove the oil drain plug when the diesel engine is still hot. Be careful of hot oil and hot engine as you may get burned. The bolt is located at the bottom of the cylinder. After draining the oil, put the bolt back and tighten it. Then fill with the proper engine oil to the proper level.

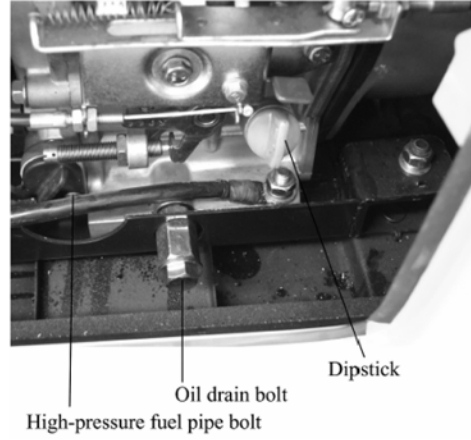

3-1.2 Air filter maintenance schedule

1. Clean air-filter every 6 months or 500 hours of operation.
2. If necessary, exchange it.
3. Do not use detergent to clean air filter element.

Note: Never start the engine without the air filter. This can cause serious damage to the engine if foreign objects enter the intake system. Always change the air filter on time.

3-1.3 Fuel filter maintenance

1. The fuel filter should be cleaned often to keep the engine running at maximum performance.
2. The recommended time period for cleaning the fuel filter is 6 months or 500 hours of operation.
 - a. To do this, first drain the fuel from the fuel tank.
 - b. Loosen the small screws on the fuel switch and remove the fuel filter from the port. Use diesel fuel to clean the fuel filter. Also, remove the fuel injector and clean the carbon deposit around it. The recommended time period for this is 3 months or 100 hours.

3-1.4 Cylinder head bolt tensions

The cylinder head bolts should be tightened to specifications please refer to the diesel engine manual for specifications and the special tools required to do this.

3-1.5 Battery check

Make sure the battery acid is full. The engine uses a 12V battery. Due to numerous starting cycles, the battery acid may be used up. Also, before filling, verify that the battery is not damaged in any way. Add distilled water to the battery when filling. Perform checks on the battery once a month.

3-2 Storing for long periods of time

If your generator needs to be stored for long periods of time, the following preparations should be made.

1. Start the diesel engine for 3 minutes then stop it.
2. When the engine is still hot, change the engine oil with new engine oil of the proper grade.
3. For electric started generator, press the decompression handle down and crank the engine for 2-3 seconds. To do this, put the starter switch in the "Start" position. (Do not start the diesel engine)
4. Clean the engine and store it in a dry place.

CHAPTER 4 TROUBLESHOOTING

4-1 Troubleshooting procedures

Causes of malfunction		Remedy
Diesel cannot be started.	Not enough fuel	Add enough fuel
	The switch of fuel is not at "OPEN" position.	Turn the switch of fuel to "OPEN" position.
	High-pressure pump and nozzle do not inject fuel or the injected amount is less.	Disassemble the nozzle and adjust it at test table.
	Speed control lever is not at "RUN" position.	Turn speed control lever to "RUN" position.
	Check level of lubrication oil.	The standard oil amount of lubricating oil should be between high graduation "H" and low graduation "L".
	It is not quick and powerful to pull reactive starter.	Start diesel engine in accordance with the requirements of "start operation procedures".
	Nozzle exist dirt.	Clean the nozzle.
	Accumulator has not electricity.	Charge the accumulator or exchange it.
Generator cannot generate electricity and has not welding voltage	Master switch (NFB) is not be switched on.	Turn master switch handle to "ON" position.
	Carbon brush of generator was worn. The contact is bad.	Exchange the carbon brush.
	The contact of socket is bad.	Adjust the contact feet of socket.
	The rated revolution of engine cannot be reached.	Make it reach to the rated revolution in accordance with the requirements.
	AVR automatic governor is damaged.	Exchange it.
	The potentiometer of current regulation for electric welding is damaged.	Exchange it.

If you are still having trouble, please contact with your nearest dealer or with our company directly if necessary.

4-2 Questions and doubts

If you do not understand anything or have any questions, please feel free to contact your local dealer or with our company directly. Below is a list of some information you should have ready before contacting your local dealer or us.

1. Model of diesel engine generator and engine model number.
2. State of residency.
3. Number of hours of operating equipment along with the problem that occurred.
4. A detailed condition and time when the problem occurred, in other words, climate and atmosphere.

Table 5-2. Please refer to Figure 5-2

Number	Part Description	Quantity	Part Code
1	Nut M4(GB/T6170-2000)	6	1000-C-001
2	Electric start switch	1	1000-C-002
3	Square American type-socket	1	1000-C-003
4	Overload protector(20A)	1	1000-C-004
4-1	Overload protector(30A)	1	1000-C-004-1
5	B-type aluminum panel	1	1000-C-005
6	Bolt M4×12(GB/T819.1-2000)	6	1000-C-006
7	Bolt M6×10 (GB/T819.1-2000)	4	1000-C-007
8	Voltmeter	1	1000-C-008
9	Bolt M3×16(GB823-88)	2	1000-C-009
10	Digital Timing	1	1000-C-010
11	Red wire holder(107)	1	1000-C-011
12	Black wire holder(107)	1	1000-C-012
13	Bolt M4×25(GB/T818)	2	1000-C-013
14	plate Washer4	9	1000-C-014
15	Nut M6 (GB/T6170)	2	1000-C-015
16	DC fuse assembly	2	1000-C-016
17	Nut M3 (GB/T6170-2000)	2	1000-C-017
18	Transfer switch302/25A	1	1000-C-018
19	American type 4-hole unit loose socket	1	1000-C-019
20	Bolt M6×26 (GB/T5787-1996)	1	1000-C-020
21	3-hole unit loose socket	1	1000-C-021
22	Breaker(DZ216-63/2P/18.5A)	1	1000-C-022
23	Nut M4 (GB/T6170-2000)	9	1000-C-023
24	Indicating lamp of power supply(12V)	1	1000-C-025
25	Low-oil protection indicating lamp(12V)	1	1000-C-026
26	2P support of breaker	1	1000-C-027
27	Fuse 10A	2	1000-C-028
28	Key	1	1000-C-029
29	bolt to the grounded	1sets	1000-C-030
30	rectifier(12V)	1	1000-C-031

Figure 5-3. Generator head assembly

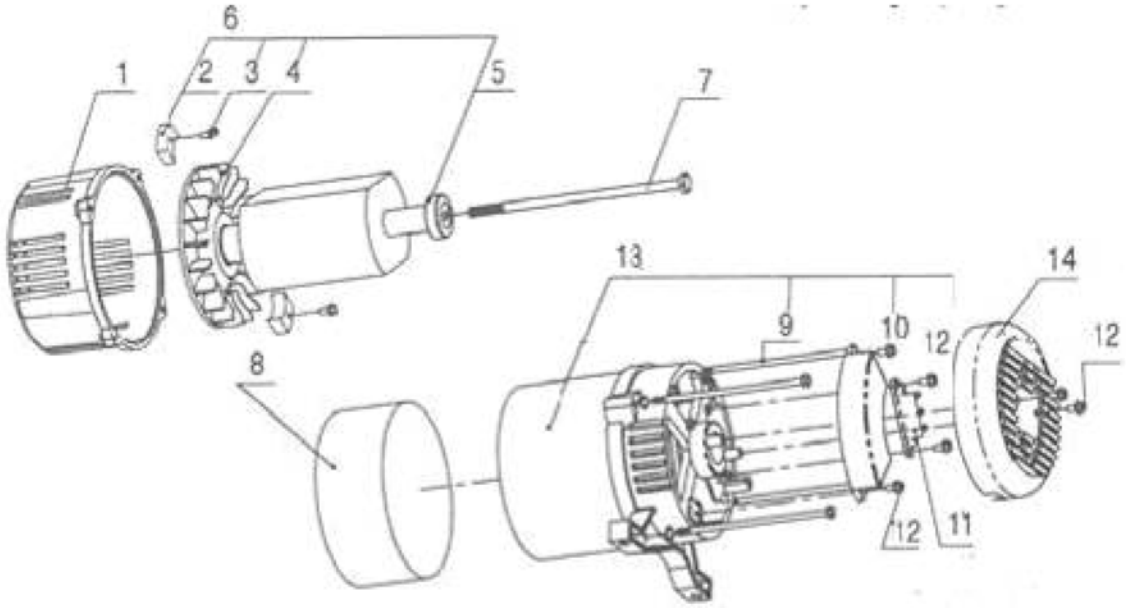

Table 5-3. Please refer to figure 5-3

Number	Part Description	Quantity	Part Code
1	Front end cover	1	1000-B-001
2	Diode 3510	1	1000-B-002
3	Bolt M5 x 16	2	1000-B-003
4	Fan Blade	1	1000-B-004
5	Bearing 6204(GB/T 307)	1	1000-B-005
6	Rotor Unit	1	1000-B-006
7	Center bolt M10 x 216 (GB/T5789-1986)	1	1000-B-007
8	Guard board of motor	1	1000-B-008
9	Installing bolt M6×180(GB/T5789-1986)	4	1000-B-009
10	Capacitance 30mf	1	1000-B-010
11	Wiring seat	1	1000-B-011
12	Heterotypic bolt M5×14	6	1000-B-012
13	Stator unit	1	1000-B-013
14	Dust cover	1	1000-B-014